



US009269304B2

(12) **United States Patent**  
**Qian et al.**

(10) **Patent No.:** **US 9,269,304 B2**  
(45) **Date of Patent:** **Feb. 23, 2016**

(54) **PIXEL CIRCUIT FOR ORGANIC LIGHT EMITTING DISPLAY AND DRIVING METHOD THEREOF, ORGANIC LIGHT EMITTING DISPLAY**  
(71) Applicant: **Shanghai Tianma Micro-Electronics Co., Ltd.**, Shanghai (CN)  
(72) Inventors: **Dong Qian**, Shanghai (CN); **Hanyu Gu**, Shanghai (CN)  
(73) Assignee: **Shanghai Tianma Micro-Electronics Co., Ltd.**, Shanghai (CN)  
(\* ) Notice: Subject to any disclaimer, the term of this patent is extended or adjusted under 35 U.S.C. 154(b) by 201 days.

(21) Appl. No.: **13/898,395**

(22) Filed: **May 20, 2013**

(65) **Prior Publication Data**  
US 2014/0176404 A1 Jun. 26, 2014

(30) **Foreign Application Priority Data**  
Dec. 26, 2012 (CN) ..... 2012 1 0577002

(51) **Int. Cl.**  
**G09G 3/32** (2006.01)  
**H01L 27/32** (2006.01)  
(52) **U.S. Cl.**  
CPC ..... **G09G 3/3266** (2013.01); **G09G 3/3233** (2013.01); **G09G 3/3258** (2013.01); **H01L 27/3276** (2013.01); **H01L 27/3297** (2013.01); **G09G 2300/0439** (2013.01); **G09G 2300/0819** (2013.01); **G09G 2300/0861** (2013.01); **G09G 2320/0233** (2013.01); **G09G 2320/045** (2013.01)

(58) **Field of Classification Search**  
CPC ..... G09G 3/3233; G09G 3/3259; G09G 2300/0439  
See application file for complete search history.

(56) **References Cited**  
**U.S. PATENT DOCUMENTS**  
2009/0167648 A1 \* 7/2009 Jeon ..... G09G 3/3233 345/76  
2010/0073266 A1 3/2010 Na et al.  
2011/0227885 A1 \* 9/2011 Chung ..... G09G 3/3241 345/204

**FOREIGN PATENT DOCUMENTS**  
EP 1939846 A2 7/2008  
KR 1020100102872 5/2012

**OTHER PUBLICATIONS**  
European Search Report of EP Application No. 13165100.2, mailed Feb. 2, 2014, 7 pages total.

\* cited by examiner  
*Primary Examiner* — Gerald Johnson  
*Assistant Examiner* — Christopher Kohlman  
(74) *Attorney, Agent, or Firm* — Alston & Bird LLP

(57) **ABSTRACT**  
A pixel circuit for an organic light emitting display includes first, second, third, fourth, fifth, and sixth MOS transistors, a first capacitor, and an organic light emitting diode. During an initialization stage, the sixth MOS transistor is turned on, and a reference voltage is transmitted to the gate electrode of the second MOS transistor. During a data-writing stage, the first MOS transistor is turned on and a data signal is transmitted to the first terminal of the first capacitor, the fourth MOS transistor is turned on and the other MOS transistors are turned off. During a light emitting stage, the fifth MOS transistor is turned on and the voltage at the gate of the second MOS transistor is based on the data signal. As a result, the third MOS transistor generates a drive current based on the data signal.

**4 Claims, 5 Drawing Sheets**

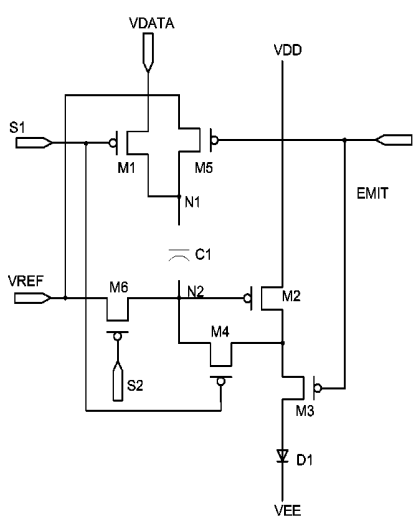

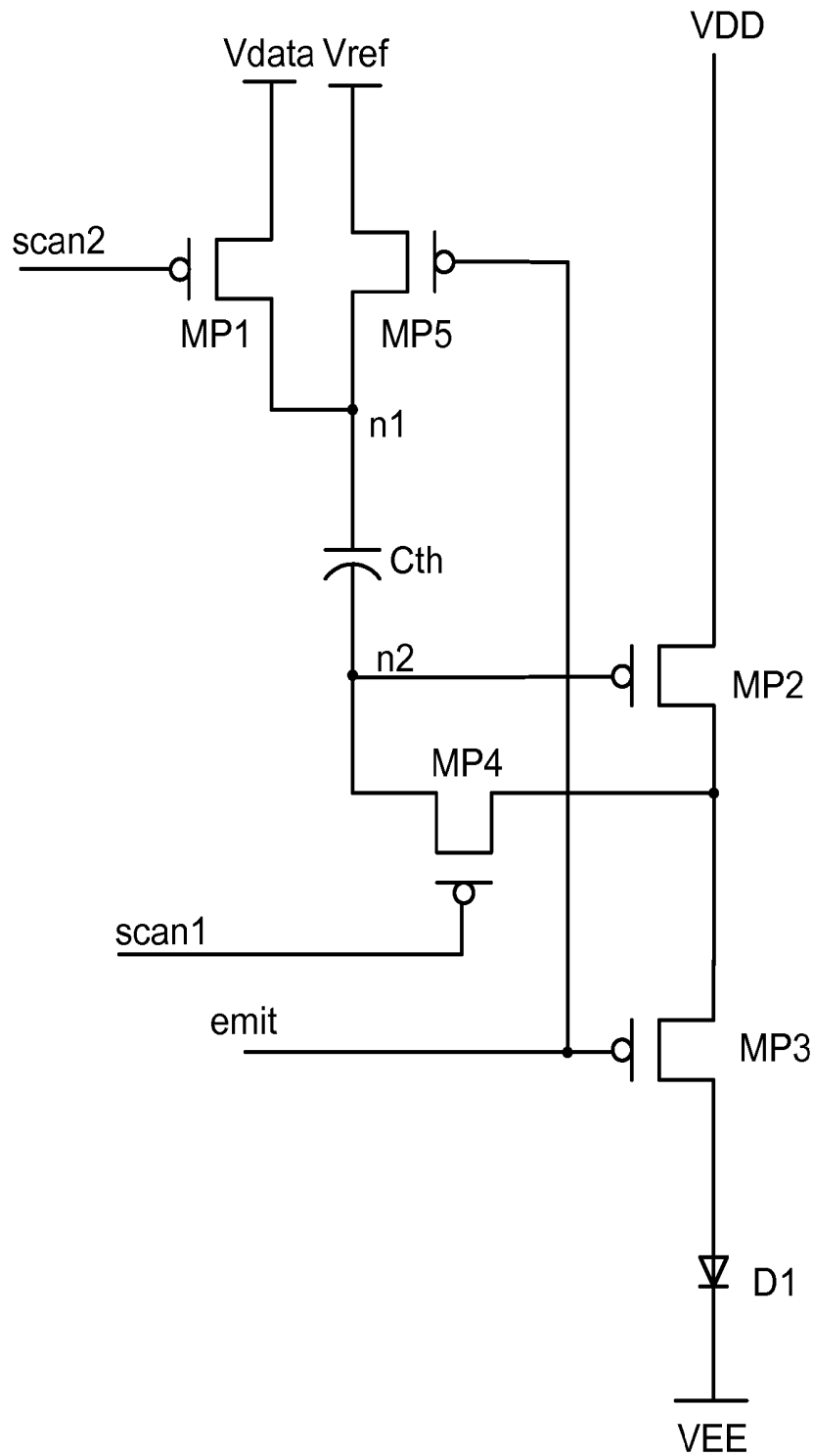

FIG. 1

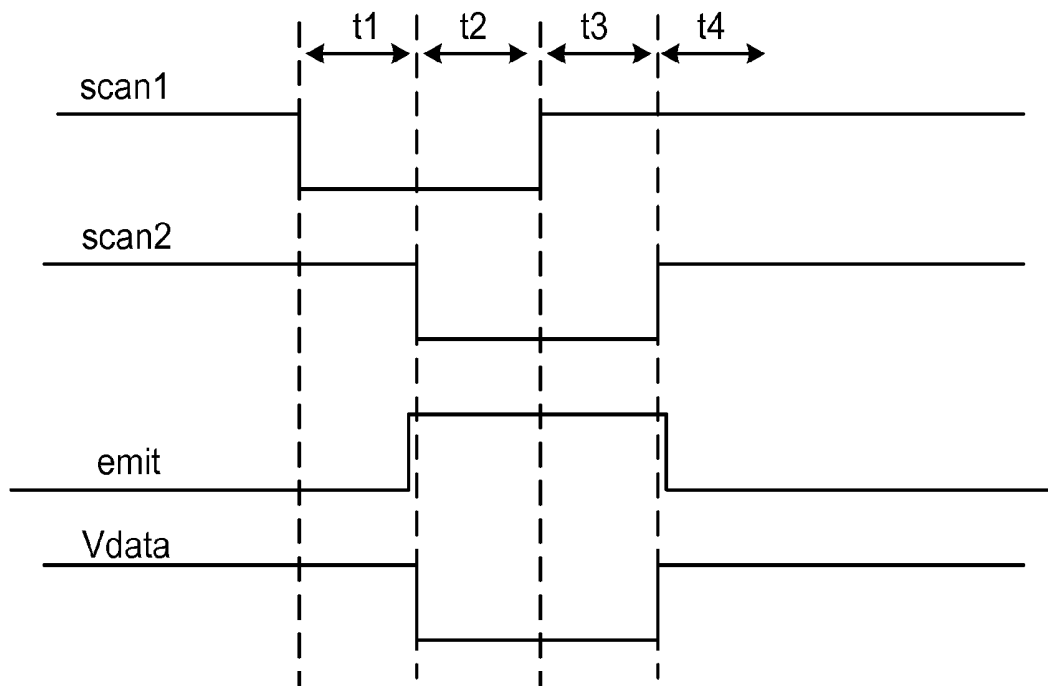

FIG. 2

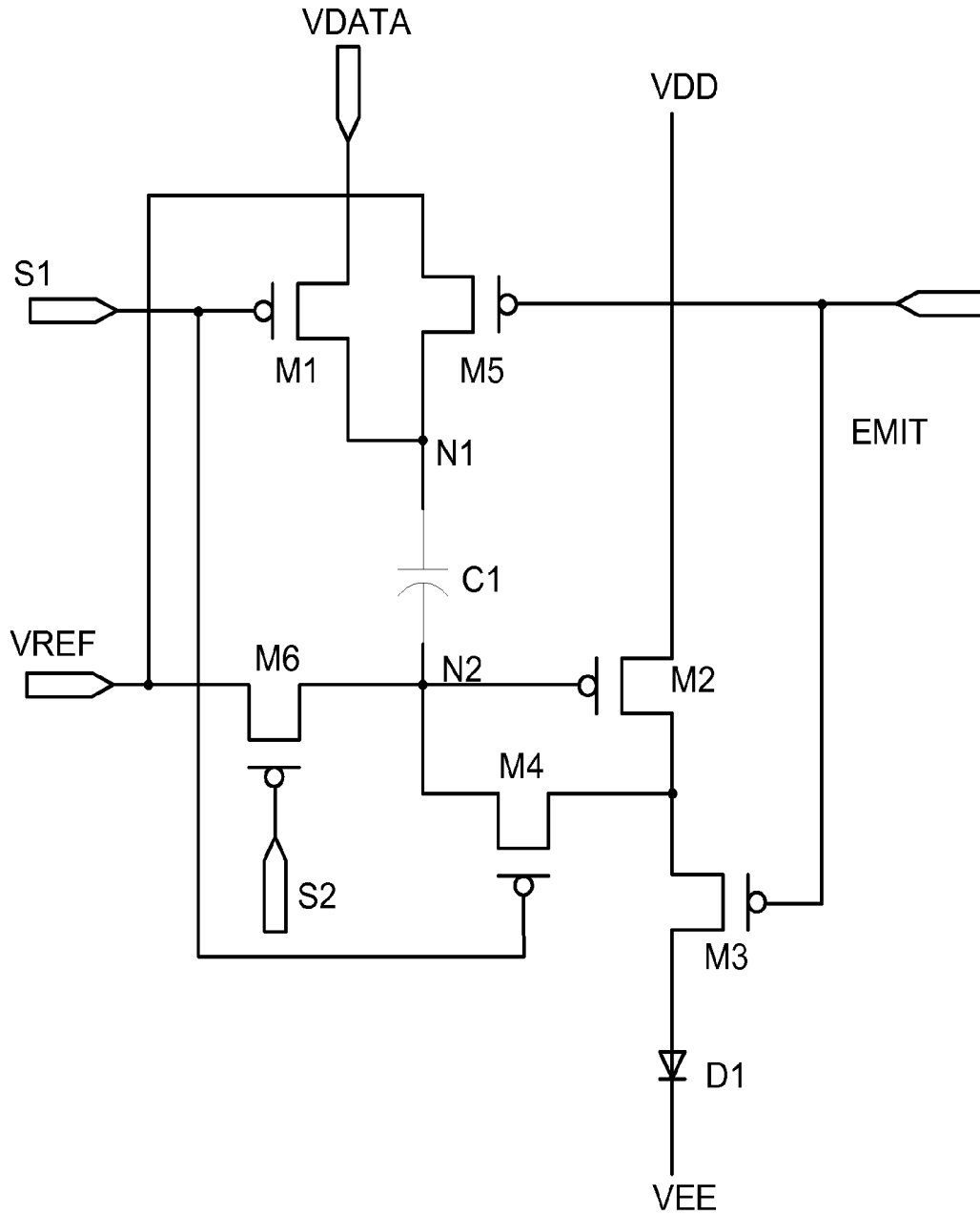

FIG. 3

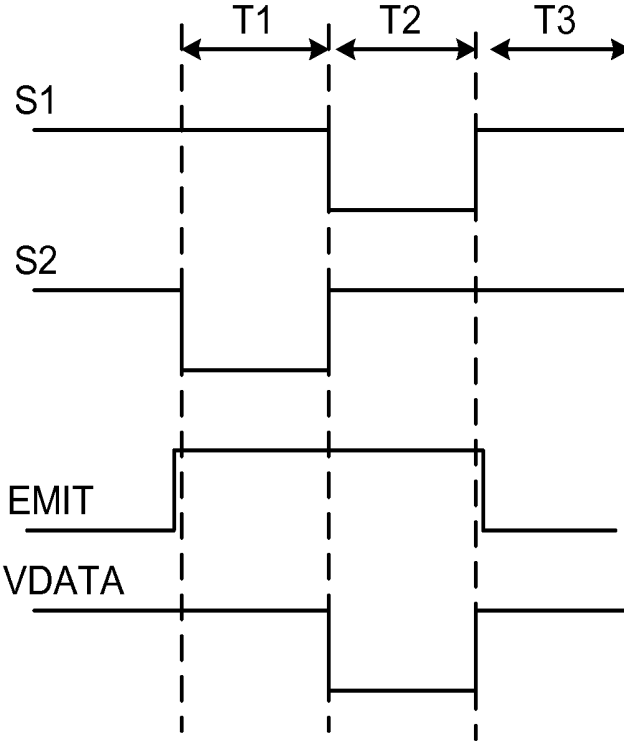

FIG. 4

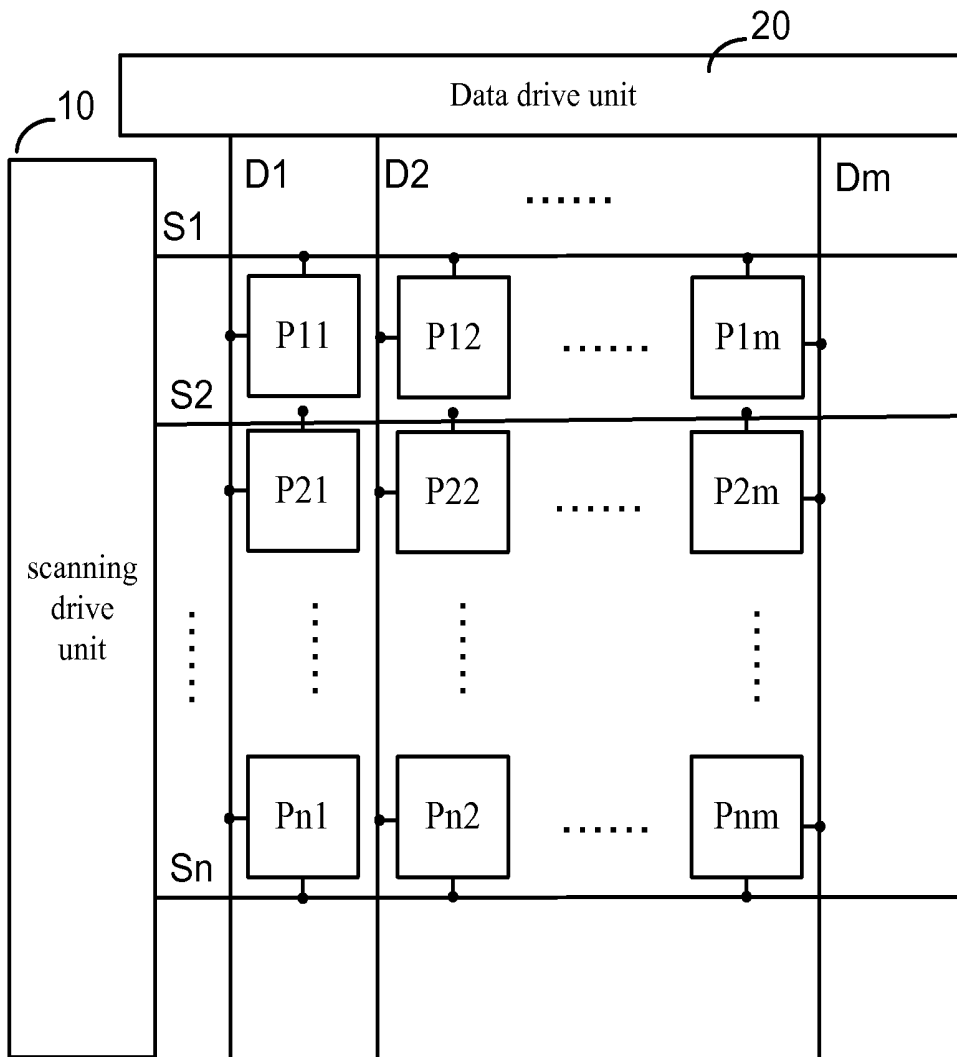

FIG. 5

**PIXEL CIRCUIT FOR ORGANIC LIGHT  
EMITTING DISPLAY AND DRIVING  
METHOD THEREOF, ORGANIC LIGHT  
EMITTING DISPLAY**

CROSS-REFERENCES TO RELATED  
APPLICATIONS

This application claims priority to Chinese patent application No. 201210577002.8 titled "PIXEL CIRCUIT FOR ORGANIC LIGHT EMITTING DISPLAY AND DRIVING METHOD THEREOF, ORGANIC LIGHT EMITTING DISPLAY" and filed with State Intellectual Property Office of PRC on Dec. 26, 2012, which is incorporated herein by reference in its entirety.

FIELD OF THE INVENTION

The present invention relates to organic light emitting displays, and more particularly to a pixel circuit for an organic light emitting display, a driving method thereof, and the organic light emitting display.

BACKGROUND OF THE INVENTION

With the continuous development of multimedia devices, the organic light emitting diode (OLED) has been increasingly used in high performance displays. In order to be adapted to large display size, a shorter driving time for a single pixel is required for a traditional passive matrix OLED. Therefore, an increased transient current is needed, resulting in increased power consumption. At the same time, the use of large current may lead to a too large voltage drop in a pixel array, so that the operation voltage of the OLED is too high and the power efficiency is reduced. However, in the active matrix organic light emitting diode (AMOLED), the problems are well solved by progressively scanning input OLED current line by line.

In AMOLED devices, pixel circuits formed with polysilicon thin film transistors are usually used to provide current for the OLED device. Compared with amorphous silicon thin film transistors, polysilicon thin film transistors have higher mobility and more stable characteristics. Accordingly, they are more suitable for AMOLED displays. However, due to the limitation of the crystallization process, the polysilicon thin film transistors made on a large glass substrate usually have heterogeneity in electrical parameters such as threshold voltage and mobility, and the heterogeneity may lead to differences in the current and brightness of the OLED display device.

In addition, in the application of large size displays, due to the resistance of the power line for the backplane and the fact that drive current for all the pixel units is supplied by the same power line, the supply voltage in a region closer to the power supply is higher than that in regions farther from the power supply in the backplane. This phenomenon is called IR Drop.

Given the correlation of the current with the supply voltage, the IR Drop may also cause current differences in different regions, and accordingly the OLED display devices in different regions have different brightness.

In the related art, a variety of technical solutions are utilized to solve the problem of brightness differences in the OLED display devices. For example, a South Korea patent application No. 1020100102872 disclosed a pixel compensation circuit. However, there are still many problems in the

existing technical solutions, such as a large number of signal lines and complex peripheral drive circuits.

BRIEF SUMMARY OF THE INVENTION

5

One inventive aspect is a pixel circuit for an organic light emitting display. The pixel circuit includes an organic light emitting diode, a first MOS transistor, including a gate electrode, a first electrode, and a second electrode, and a second MOS transistor, including a gate electrode, a first electrode, and a second electrode. The first electrode of the second MOS transistor is coupled to a first power supply. The pixel circuit also includes a third MOS transistor, including a gate electrode, a first electrode, and a second electrode, where the first electrode of the third MOS transistor is coupled to the second electrode of the second MOS transistor, and the second electrode of the third MOS transistor is coupled to a second power supply via the organic light emitting diode. The pixel circuit also includes a fourth MOS transistor, including a gate electrode, a first electrode, and a second electrode, where the first electrode of the fourth MOS transistor is coupled to the gate electrode of the second MOS transistor, and the second electrode of the fourth MOS transistor is coupled to the second electrode of the second MOS transistor. The pixel circuit also includes a fifth MOS transistor, including a gate electrode, a first electrode, and a second electrode, a sixth MOS transistor, including a gate electrode, a first electrode, and a second electrode, where the second electrode of the sixth MOS transistor is coupled to the gate electrode of the second MOS transistor. The pixel circuit also includes a first capacitor, including first and second terminals, where the first terminal of the first capacitor is coupled to the second electrode of the first MOS transistor and is coupled to the second electrode of the fifth MOS transistor, and the second terminal is coupled to the gate electrode of the second MOS transistor and is coupled to the first electrode of the fourth MOS transistor. The gate electrode of the first

MOS transistor receives a first scanning signal, the first electrode of the first MOS transistor receives a data signal, the gate electrode of the third MOS transistor receives a control signal, the gate electrode of the fourth MOS transistor receives the first scanning signal, the gate electrode of the fifth MOS transistor receives the control signal, the first electrode of the fifth MOS transistor receives a reference voltage, the gate electrode of the sixth MOS transistor receives a second scanning signal, and the first electrode of the sixth MOS transistor receives the reference voltage.

Another inventive aspect is a driving method for a pixel circuit. The pixel circuit includes an organic light emitting diode, a first MOS transistor, including a gate electrode, a first electrode, and a second electrode, and a second MOS transistor, including a gate electrode, a first electrode, and a second electrode. The first electrode of the second MOS transistor is coupled to a first power supply. The pixel circuit also includes a third MOS transistor, including a gate electrode, a first electrode, and a second electrode, where the first electrode of the third MOS transistor is coupled to the second electrode of the second MOS transistor, and the second electrode of the third MOS transistor is coupled to a second power supply via the organic light emitting diode. The pixel circuit also includes a fourth MOS transistor, including a gate electrode, a first electrode, and a second electrode, where the first electrode of the fourth MOS transistor is coupled to the gate electrode of the second MOS transistor, and the second electrode of the fourth MOS transistor is coupled to the second electrode of the second MOS transistor. The pixel circuit also includes a fifth MOS transistor, including a gate electrode, a

first electrode, and a second electrode, a sixth MOS transistor, including a gate electrode, a first electrode, and a second electrode, where the second electrode of the sixth MOS transistor is coupled to the gate electrode of the second MOS transistor. The pixel circuit also includes a first capacitor, including first and second terminals, where the first terminal of the first capacitor is coupled to the second electrode of the first MOS transistor and is coupled to the second electrode of the fifth MOS transistor, and the second terminal is coupled to the gate electrode of the second MOS transistor and is coupled to the first electrode of the fourth MOS transistor. The method includes during an initialization stage, turning off the first MOS transistor and the fourth MOS transistor via the first scanning signal, turning off the third MOS transistor and the fifth MOS transistor via the control signal, and turning on the sixth MOS transistor via the second scanning signal, where the reference voltage is transmitted to the gate electrode of the second MOS transistor through the sixth MOS transistor.

Another inventive aspect is an organic light emitting display including a scanning drive unit, a data drive unit, N scan lines, M data lines, and a plurality of pixel circuits. Each of the pixel circuits includes an organic light emitting diode, a first MOS transistor, including a gate electrode, a first electrode, and a second electrode, and a second MOS transistor, including a gate electrode, a first electrode, and a second electrode. The first electrode of the second MOS transistor is coupled to a first power supply. Each pixel circuit also includes a third MOS transistor, including a gate electrode, a first electrode, and a second electrode, where the first electrode of the third MOS transistor is coupled to the second electrode of the second MOS transistor, and the second electrode of the third MOS transistor is coupled to a second power supply via the organic light emitting diode. Each pixel circuit also includes a fourth MOS transistor, including a gate electrode, a first electrode, and a second electrode, where the first electrode of the fourth MOS transistor is coupled to the gate electrode of the second MOS transistor, and the second electrode of the fourth MOS transistor is coupled to the second electrode of the second MOS transistor. Each pixel circuit also includes a fifth MOS transistor, including a gate electrode, a first electrode, and a second electrode, a sixth MOS transistor, including a gate electrode, a first electrode, and a second electrode, where the second electrode of the sixth MOS transistor is coupled to the gate electrode of the second MOS transistor. Each pixel circuit also includes a first capacitor, including first and second terminals, where the first terminal of the first capacitor is coupled to the second electrode of the first MOS transistor and is coupled to the second electrode of the fifth MOS transistor, and the second terminal is coupled to the gate electrode of the second MOS transistor and is coupled to the first electrode of the fourth MOS transistor. The gate electrode of the first MOS transistor receives a first scanning signal, the first electrode of the first MOS transistor receives a data signal, the gate electrode of the third MOS transistor receives a control signal, the gate electrode of the fourth MOS transistor receives the first scanning signal, the gate electrode of the fifth MOS transistor receives the control signal, the first electrode of the fifth MOS transistor receives a reference voltage, the gate electrode of the sixth MOS transistor receives a second scanning signal, and the first electrode of the sixth MOS transistor receives the reference voltage. The scanning drive unit is configured to provide scanning signals to respective scan lines, the data drive unit is configured to provide data signals to respective data lines, and the plurality

of the pixel circuits are respectively arranged in pixel areas formed near intersections of the scan lines and the data lines.

#### BRIEF DESCRIPTION OF THE DRAWINGS

FIG. 1 is a schematic diagram of a pixel circuit according to an embodiment in the prior art;

FIG. 2 is a timing diagram of driving signals for the pixel circuit shown in FIG. 1;

FIG. 3 is a schematic diagram of a pixel circuit according to an embodiment of the present invention;

FIG. 4 is a timing diagram of driving signals for the pixel circuit shown in FIG. 3; and

FIG. 5 is a schematic structural diagram of an organic light emitting display according to an embodiment of the present invention.

#### DETAILED DESCRIPTION OF THE INVENTION

Particular embodiments of the invention are illustrated herein in conjunction with the drawings.

Various details are set forth herein as they relate to certain embodiments. However, the invention can also be implemented in other ways different from the ways described herein, and modifications can be made by those skilled in the art without departing from the invention. Therefore, the invention is not limited to particular embodiments disclosed hereinafter.

As described above, AMOLED display devices have the problem of uneven brightness due to the influence of the threshold voltages of the polysilicon thin film transistors and the IR drop on the power line for the backplane. In order to solve these problems, a voltage driven pixel circuit including five polysilicon thin film transistors and one capacitor (5T1C) is usually used in the prior art. As shown in FIG. 1, the pixel circuit of the prior art includes a first PMOS transistor MP1, a second PMOS transistor MP2, a third PMOS transistor MP3, a fourth PMOS transistor MP4, a fifth PMOS transistor MP5, a capacitor Cth and an organic light emitting diode D1.

The gate electrode of the first PMOS transistor MP1 receives a scanning signal scan2, the source electrode of the first PMOS transistor MP1 receives a data signal Vdata, and the drain electrode of the first PMOS transistor MP1 is connected to the first terminal n1 of the capacitor Cth. The second terminal n2 of the capacitor Cth is connected to the gate electrode of the second PMOS transistor MP2. The source electrode of the second PMOS transistor MP2 receives a first power supply VDD, and the drain electrode of the second PMOS transistor MP2 is connected to the source electrode of the third PMOS transistor MP3. The gate electrode of the third PMOS transistor MP3 receives a control signal "emit", and the drain electrode of the third PMOS transistor MP3 is connected to the anode of the organic light emitting diode D1. The cathode of the organic light emitting diode D1 is connected to a second power supply VEE. The gate electrode of the fourth PMOS transistor MP4 receives a scanning signal scan1, the source electrode of the fourth PMOS transistor MP4 is connected to the second terminal n2 of the capacitor Cth, and the drain electrode of the fourth PMOS transistor MP4 is connected to the drain electrode of the second PMOS transistor MP2. The gate electrode of the fifth PMOS transistor MP5 receives the control signal "emit", the source electrode of the fifth PMOS transistor MP5 receives a reference voltage Vref, and the drain electrode of the fifth PMOS transistor MP5 is connected to the first terminal n1 of the capacitor Cth.

FIG. 2 shows a timing diagram of driving signals for the pixel circuit in FIG. 1. The operational principle of the pixel circuit shown in FIG. 1 is described in further detail in conjunction with the FIG. 2 as follows.

In Stage t1, both the scanning signal scan1 and the control signal "emit" are at a low level. Therefore, the second PMOS transistor MP2, the third PMOS transistor MP3, the fourth PMOS transistor MP4 and the fifth PMOS transistor MP5 are turned on. In this Stage, the second terminal n2 of the capacitor Cth is pulled down to a low potential, and the first terminal n1 of the capacitor Cth is applied with voltage Vref.

In Stage t2, the control signal "emit" is turned into high level, and the third PMOS transistor MP3 and the fifth PMOS transistor MP5 are turned off. In addition, the scanning signal scan1 is turned to a low level. Because the scanning signal scan1 and the scanning signal scan2 are in the low level, the first PMOS transistor MP1 and the fourth PMOS transistor MP4 are on. In this case, the first terminal n1 of the capacitor Cth is connected to the data signal Vdata, and a voltage (VDD-Vth) based on the threshold voltage Vth of the second PMOS transistor MP2 is developed at the second terminal n2 of the capacitor Cth. The voltage difference across the capacitor Cth is Vdata-(VDD-Vth).

In Stage t3, the scanning signal scan1 is turned to high level, and the fourth PMOS transistor MP4 is turned off.

In Stage t4, the control signal "emit" is turned to low level. Accordingly, the third PMOS transistor MP3 and the fifth PMOS transistor MP5 are turned on. In this case, the voltage at the first terminal n1 of the capacitor Cth becomes Vref. According to the law of charge conservation, the voltage at the second terminal n2 of the capacitor Cth becomes Vref-Vdata+(VDD-Vth), and the second PMOS transistor MP2 is turned on or off according to the voltage at the second terminal n2.

The voltage difference between the source electrode and the gate electrode of the second PMOS transistor MP2 is  $V_{sg} = VDD - Vref + Vdata - (VDD - Vth) = Vdata - Vref + Vth$ . It can be concluded that the current flowing through the second PMOS transistor MP2 is  $I_{m2} = k(Vdata - Vref)^2$ , where k is a constant coefficient which is related to the mobility, the width to length ratio and the gate-source capacitance value of the MOS transistor. Thus the compensation for the threshold voltage Vth and the first supply voltage VDD is achieved.

However, in the pixel circuit described above, there is an overlap between the scanning signal scan1 and the scanning signal scan2 in time sequence. Specifically, referring to FIG. 2, both the scanning signal scan1 and the scanning signal scan2 are in low level in Stage t2. The structure and operation of the peripheral drive circuit for the pixel circuit with such structure is, therefore, complicated.

In addition, in the pixel circuit described above, it is necessary to continuously provide the data signal Vdata with a high potential to the drain electrode of the first PMOS transistor MP1. That is to say, the data line connected to the first PMOS transistor MP1 can not be left floating, otherwise the compensation for the threshold voltage Vth and the first supply voltage VDD can not be achieved in this circuit. This is because the drain electrode of the first PMOS transistor MP1 is connected to the drain electrode of the fifth PMOS transistor MP5. In Stage t1, when the fifth PMOS transistor MP5 is turned on, the voltage at the drain electrode of the fifth PMOS transistor MP5 is Vref. If the data line is left floating, a leakage current may occur in the drain electrode of the first PMOS transistor MP1, leading to an unstable voltage at the first terminal n1 of the capacitor Cth. Hence, the voltage difference across the capacitor Cth may change, and thus the compensation for the threshold voltage and the first supply

voltage can not be actually achieved. Moreover, the need to continuously provide the data signal with high potential increases both the difficulty in IC development and the power consumption of the circuit.

The present invention provides a pixel circuit for an organic light emitting display, whereby the waveform of each driving signal can be defined to simplify the structure of the drive circuit and the power consumption of the circuit can be reduced. Specifically, FIG. 3 shows a schematic circuit diagram of a pixel circuit for an organic light emitting display according to an embodiment of the present invention.

As shown in FIG. 3, the pixel circuit according to the embodiment of the present invention includes a first MOS transistor M1, a second MOS transistor M2, a third MOS transistor M3, a fourth MOS transistor M4, a fifth MOS transistor M5, a sixth MOS transistor M6, a first capacitor C1 and an organic light emitting diode D1.

The gate electrode of the first MOS transistor M1 receives a first scanning signal S1, the first electrode of the first MOS transistor M1 receives a data signal VDATA, and the second electrode of the first MOS transistor M1 is connected to the first terminal N1 of the first capacitor C1. The second terminal N2 of the first capacitor C1 is connected to the gate electrode of the second MOS transistor M2. The first electrode of the second MOS transistor M2 is connected to a first power supply VDD, and the second electrode of the second MOS transistor M2 is connected to the first electrode of the third MOS transistor M3. The gate electrode of the third MOS transistor M3 receives a control signal EMIT, and the second electrode of the third MOS transistor M3 is coupled to a second power supply VEE via the organic light emitting diode D1. The first electrode of the fourth MOS transistor M4 is connected to the second terminal N2 of the first capacitor C1, the second electrode of the fourth MOS transistor M4 is connected to the second electrode of the second MOS transistor M2, and the gate electrode of the fourth MOS transistor M4 receives the first scanning signal S1. The gate electrode of the fifth MOS transistor M5 receives the control signal EMIT, the first electrode of the fifth MOS transistor M5 receives a reference voltage VREF, and the second electrode of the fifth MOS transistor M5 is connected to the first terminal N1 of the first capacitor C1. The gate electrode of the sixth MOS transistor M6 receives a second scanning signal S2, the first electrode of the sixth MOS transistor M6 receives the reference voltage VREF, and the second electrode of the sixth MOS transistor M6 is connected to the gate electrode of the second MOS transistor M2.

Specifically, in this embodiment, the first MOS transistor, the second MOS transistor, the third MOS transistor, the fourth MOS transistor, the fifth MOS transistor and the sixth MOS transistor are all PMOS transistors. The first electrode refers to the source electrode of each of the PMOS transistors. The second electrode refers to the drain electrode of each of the PMOS transistors.

It should be noted that in other embodiments, the first MOS transistor, the second MOS transistor, the third MOS transistor, the fourth MOS transistor, the fifth MOS transistor and the sixth MOS transistor may also be NMOS transistors. Of course, the invention is not limited thereto, and other variations can be made in the first MOS transistor to the sixth MOS transistor by those skilled in the art. For example, one or more of the transistors may be PMOS transistors, and one or more other transistors may be NMOS transistors.

FIG. 4 shows a timing diagram of the scanning signals and the control signal for the pixel circuit according to the present invention. The operational principle of the pixel circuit

according to the present invention will be described in further detail in conjunction with the FIG. 3 and the FIG. 4 below.

Referring to the FIG. 4, in Stage T1, both the first scanning signal S1 and the control signal EMIT are in high level. Accordingly, the first MOS transistor M1, the third MOS transistor M3, the fourth MOS transistor M4 and the fifth MOS transistor M5 are turned off. Furthermore, the second scanning signal S2 is in low level and the sixth MOS transistor M6 is turned on. The reference voltage VREF is transmitted to the gate electrode of the second MOS transistor M2 through the sixth MOS transistor M6, and the voltage at the second terminal N2 of the first capacitor C1 is VREF.

In Stage T2, the first scanning signal S1 is turned to low level, and thus the first MOS transistor M1 is turned on. In response, the voltage at the first terminal N1 of the first capacitor C1 becomes VDATA. Furthermore, the fourth MOS transistor M4 is turned on, so that a diode connection is formed in the second MOS transistor M2. In this case, the voltage at the second terminal N2 of the first capacitor C1 is  $VDD - V_{th}$  ( $V_{th}$  is the threshold voltage of the MOS transistor), and thus the voltage difference across the first capacitor C1 is  $VDATA - (VDD - V_{th})$ . Moreover, the second scanning signal S2 is turned to high level, and thus the sixth MOS transistor M6 is turned off. The control signal EMIT is still high level, and thus the third MOS transistor M3 and the fifth MOS transistor M5 are turned off.

In Stage T3, the first scanning signal S1 is turned to high level, and thus the first MOS transistor M1 and the fourth MOS transistor M4 are turned off. The second scanning signal S2 is in high level, and thus the sixth MOS transistor M6 is turned off. The control signal EMIT is turned to low level, and thus the third MOS transistor M3 and the fifth MOS transistor M5 are turned on. The voltage at the first terminal N1 of the first capacitor C1 is reset because the fifth MOS transistor M5 is turned on. Accordingly, the voltage at the first terminal N1 of the first capacitor C1 is VREF. According to the law of charge conservation, the voltage at the second terminal N2 of the first capacitor C1 is  $VREF - VDATA + (VDD - V_{th})$ . Accordingly, the voltage difference between the source electrode and the gate electrode of the second MOS transistor M2 is  $V_{sg} = VDD - VREF + VDATA - (VDD - V_{th}) = VDATA - VREF + V_{th}$ . It can be concluded that the current flowing through the second MOS transistor M2 is  $I_{m2} = k(V_{data} - V_{ref})^2$ , where k is a constant coefficient which is related to the mobility, the width to length ratio and the gate-source capacitance value of the MOS transistor. The organic light emitting diode D1 is driven to emit light when the third MOS transistor M3 is turned on.

It can be known from the above mentioned operational principle that the compensation for the threshold voltage  $V_{th}$  and the first supply voltage VDD has been achieved through the pixel circuit according to the embodiment of the present invention. Moreover, it can be seen from the FIG. 4 that the first scanning signal S1 and the second scanning signal S2 are independent of each other in time sequence and are not both turned on at the same time. Accordingly, a more simple drive circuit can be used to provide the drive signals, and the operation of the drive circuit is more convenient. In addition, since the drive signals are independent of each other in the time sequence, the multi-channel selection of the pixel circuit can be achieved so as to improve the integrity and convenience of the pixel circuit.

In addition, according to the embodiment of the present invention, in an initialization stage (i.e. Stage T1), it is not necessary to continuously provide the data signal VDATA to the pixel circuit. This is because the fourth MOS transistor M4 is not turned on in the initialization stage, so there is no

resistance drop by the second PMOS transistor MP2 and the third PMOS transistor MP3 as shown in FIG. 1, but the second terminal N2 of the first capacitor C1 is charged to the potential VREF directly. Meanwhile, neither the first MOS transistor M1 nor the fifth MOS transistor M5 is turned on. Therefore the leakage current does not occur at the first terminal N1 of the first capacitor C1. Accordingly, the data line connected to the first MOS transistor M1 can be left floating. The pixel circuit with this structure reduces the difficulty in IC development and power consumption of the circuit, since it is not necessary to continuously provide the data signal VDATA with a relatively high potential.

The present invention further provides a driving method for the pixel circuit shown in FIG. 3. The driving method includes the following stages. In an initialization stage, the first MOS transistor M1 and the fourth MOS transistor M4 are turned off via the first scanning signal S1, the third MOS transistor M3 and the fifth MOS transistor M5 are turned off via the control signal EMIT, the sixth MOS transistor M6 is turned on via the second scanning signal S2, and the reference voltage VREF is transmitted to the gate electrode of the second MOS transistor M2 through the sixth MOS transistor M6.

In a data-writing stage, the first MOS transistor M1 and the fourth MOS transistor M4 are turned on via the first scanning signal S1, and the data signal VDATA is transmitted to the first terminal of the first capacitor C1 through the first MOS transistor M1, and the fourth MOS transistor M4 is turned on, resulting in a diode connection formed in the second MOS transistor M2; the sixth MOS transistor M6 is turned off via the second scanning signal S2, and the third MOS transistor M3 and the fifth MOS transistor M5 are turned off via the control signal EMIT.

In a light emitting stage, the first MOS transistor M1 and the fourth MOS transistor M4 are turned off via the first scanning signal S1, the sixth MOS transistor M6 is turned off via the second scanning signal S2, the fifth MOS transistor M5 and the third MOS transistor M3 are turned on via the control signal EMIT. The voltage across the first capacitor C1 is reset due to the turning on of the fifth MOS transistor M5, a corresponding drive current is generated by the third MOS transistor M3 based on the reset of the voltage across the first capacitor C1, and the drive current is configured to drive the organic light emitting diode D1 to emit light.

The data signal may be provided in the data-writing stage, while the data signal may be not provided in the initialization stage and the light emitting stage. In other words, the data line can be left floating in the initialization stage and the light emitting stage.

The present invention further provides an organic light emitting display. As shown in FIG. 5, the organic light emitting display includes: a scanning drive unit 10, a data drive unit 20, N scan lines (S1, S2, . . . , Sn), M data lines (D1, D2, . . . , Dm) and multiple pixel circuits (P11, P12, . . . , P1m, P21, P22, . . . , P2m, . . . , Pn1, Pn2, . . . , Pnm). The structures of the pixel circuits are similar to that of the pixel circuit shown in FIG. 3.

Specifically, the scanning drive unit 10 is configured to provide scanning signals to respective scan lines (S1, S2, . . . , Sn). The data drive unit 20 is configured to provide data signals to respective data lines (D1, D2, . . . , Dm). The multiple pixel circuits are respectively arranged in pixel areas formed by intersection of the N scan lines and the M data lines.

In each of the pixel circuits for the organic light emitting display according to the present invention, the gate electrodes of the first MOS transistor M1 and the fourth MOS transistor M4 may be both connected to the nth scan line, and the gate

electrode of the sixth MOS transistor M6 is connected to the (n+1)th scan line, where  $1 < n < N$ .

In other embodiments, the gate electrode of the first MOS transistor M1, the gate electrode of the fourth MOS transistor M4 and the gate electrode of the sixth MOS transistor M6 may be connected to the scan lines in other ways, which are not limited to the embodiment described above.

Compared with the drive circuit in the prior art, the scanning drive circuit for the organic light emitting display according to the embodiment of the present invention is simpler in structure and more convenient in operation for employing the pixel circuit shown in FIG. 3. In addition, it is not necessary to continuously provide the data signal to the data line in the initialization stage. Therefore, the power consumption of the organic light emitting display according to the embodiment of the present invention is also lower than that in the prior art.

Though the present invention is disclosed by way of specific embodiments as described above, those embodiments are not intended to limit the present invention. Based on the methods and the technical aspects disclosed above, possible variations and changes may be made to the technical solutions of the present invention by those skilled in the art without departing from the spirit and the scope of the present invention. Therefore, any change, equivalent alternation, or modification made to the above embodiments according to the principle of the present invention, which do not depart from the subject matters of the present invention, fall within the scope of protection of the present invention.

What is claimed is:

1. An organic light emitting display comprising:

a scanning drive unit;

a data drive unit;

N scan lines;

M data lines; and

a plurality of pixel circuits, each of the pixel circuits comprising:

an organic light emitting diode;

a first MOS transistor, comprising a gate electrode, a first electrode, and a second electrode;

a second MOS transistor, comprising a gate electrode, a first electrode, and a second electrode, wherein the first electrode of the second MOS transistor is coupled to a first power supply;

a third MOS transistor, comprising a gate electrode, a first electrode, and a second electrode, wherein the first electrode of the third MOS transistor is coupled to the second electrode of the second MOS transistor, and the second electrode of the third MOS transistor is coupled to a second power supply via the organic light emitting diode;

a fourth MOS transistor, comprising a gate electrode, a first electrode, and a second electrode, wherein the first electrode of the fourth MOS transistor is coupled to the gate electrode of the second MOS transistor,

and the second electrode of the fourth MOS transistor is coupled to the second electrode of the second MOS transistor;

a fifth MOS transistor, comprising a gate electrode, a first electrode, and a second electrode;

a sixth MOS transistor, comprising a gate electrode, a first electrode, and a second electrode, wherein the second electrode of the sixth MOS transistor is coupled to the gate electrode of the second MOS transistor; and

a first capacitor, comprising first and second terminals, wherein the first terminal of the first capacitor is coupled to the second electrode of the first MOS transistor and is coupled to the second electrode of the fifth MOS transistor, and the second terminal is coupled to the gate electrode of the second MOS transistor and is coupled to the first electrode of the fourth MOS transistor,

wherein the gate electrode of the first MOS transistor receives a first scanning signal, the first electrode of the first MOS transistor receives a data signal, the gate electrode of the third MOS transistor receives a control signal, the gate electrode of the fourth MOS transistor receives the first scanning signal, the gate electrode of the fifth MOS transistor receives the control signal, the first electrode of the fifth MOS transistor receives a reference voltage, the gate electrode of the sixth MOS transistor receives a second scanning signal, and the first electrode of the sixth MOS transistor receives the reference voltage,

wherein the scanning drive unit is configured to provide scanning signals to respective scan lines, the data drive unit is configured to provide data signals to respective data lines, and the plurality of the pixel circuits are respectively arranged in pixel areas formed near intersections of the scan lines and the data lines, and

wherein the gate electrodes of the first MOS transistor and the fourth MOS transistor are both coupled to an nth scan line, and the gate electrode of the sixth MOS transistor is coupled to an (n+1)th scan line, where  $1 \leq n < N$ .

2. The organic light emitting display according to claim 1, wherein the first scanning signal and the second scanning signal do not overlap.

3. The organic light emitting display according to claim 1, wherein the first MOS transistor, the second MOS transistor, the third MOS transistor, the fourth MOS transistor, the fifth MOS transistor and the sixth MOS transistor are PMOS transistors.

4. The organic light emitting display according to claim 1, wherein the first MOS transistor, the second MOS transistor, the third MOS transistor, the fourth MOS transistor, the fifth MOS transistor and the sixth MOS transistor are NMOS transistors.

\* \* \* \* \*

专利名称(译)	用于有机发光显示器的像素电路及其驱动方法，有机发光显示器		
公开(公告)号	<a href="#">US9269304</a>	公开(公告)日	2016-02-23
申请号	US13/898395	申请日	2013-05-20
[标]申请(专利权)人(译)	上海天马微电子有限公司		
申请(专利权)人(译)	上海天马微电子有限公司.		
当前申请(专利权)人(译)	上海天马微电子有限公司.		
[标]发明人	QIAN DONG GU HANYU		
发明人	QIAN, DONG GU, HANYU		
IPC分类号	G09G3/32 H01L27/32		
CPC分类号	G09G3/3266 G09G3/3233 G09G3/3258 H01L27/3276 H01L27/3297 G09G2300/0439 G09G2300/0819 G09G2300/0861 G09G2320/0233 G09G2320/045		
代理机构(译)	ALSTON & BIRD LLP		
审查员(译)	JOHNSON, GERALD		
优先权	201210577002.8 2012-12-26 CN		
其他公开文献	US20140176404A1		
外部链接	<a href="#">Espacenet</a> <a href="#">USPTO</a>		

摘要(译)

用于有机发光显示器的像素电路包括第一，第二，第三，第四，第五和第六MOS晶体管，第一电容器和有机发光二极管。在初始化阶段期间，第六MOS晶体管导通，并且参考电压被传输到第二MOS晶体管的栅极。在数据写入阶段期间，第一MOS晶体管导通并且数据信号被传输到第一电容器的第一端子，第四MOS晶体管导通而其他MOS晶体管截止。在发光阶段期间，第五MOS晶体管导通，并且第二MOS晶体管的栅极处的电压基于数据信号。结果，第三MOS晶体管基于数据信号产生驱动电流。

